

Inventory of Data Sets for AFDD Evaluation



Jessica Granderson and Guanqing Lin

Building Technology and Urban Systems Division

Lawrence Berkeley National Laboratory

February, 2019

This document provides an inventory and associated documentation of automated fault detection and diagnostics (AFDD) testing data sets created by LBNL, PNNL, NREL/ORNL, and Drexel university.

The AFDD performance testing data inventory notes key information necessary to understand the content and scope of each data set, including:

- An overview of the data set, who created it, and whether it was generated through simulation or physical experimentation
- Building and system information
 - Model or experimental facility description
 - System type and diagram
 - Control sequences
- Data points
- Input scenarios for faulted and fault-free conditions represented in the data
 - Fault types
 - Fault intensities
 - Method of fault imposition
 - Fault occurred time

All data sets use condition-based definition for ground truth. All use 1-minute measurement frequency so the data sets can be converted into input samples of any time horizon larger than 1 minute. The full inventory is presented following this summary.

1. Simulated multi-zone variable air volume AHU data set

This simulated dataset was generated by Pacific Northwest National Laboratory(PNNL) adaptive control team using their large office building model. The building model is developed using co-simulation framework - building envelope model (using EnergyPlus) and building HVAC system model (using Dymola).

1.1 Building and system information

1.1.1 Model description

The building includes three floors (Figure 1-1) . Heating and cooling are delivered by a single-duct AHU-VAV system. One AHU connected with five VAV boxes serves five zones (four exterior zones, one interior zone) respectively at one floor. A boiler, fed by natural gas, supplies hot water to the AHU heating and VAV reheating coils. Chilled water is supplied by a central chiller plant.

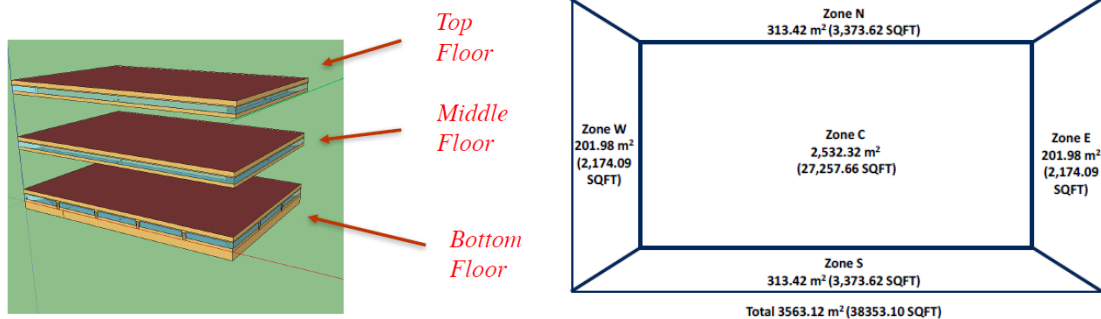

Figure 1-1. Studied DOE large office reference building and the layout of one floor

1.1.2 System type and diagram

The major components of the studied AHU located in the middle floor, shown in Figure 1-2, are supply air fan with a variable frequency drive (VFD), return fan with a VFD, cooling and heating coils, cooling and heating control valves, outdoor air (OA) and return air (RA) dampers. The equipped VAV box is a typical single-duct pressure- independent VAV box with hydronic reheat. The major components of the studied VAV boxes are reheating coil, reheating coil valve, and terminal damper.

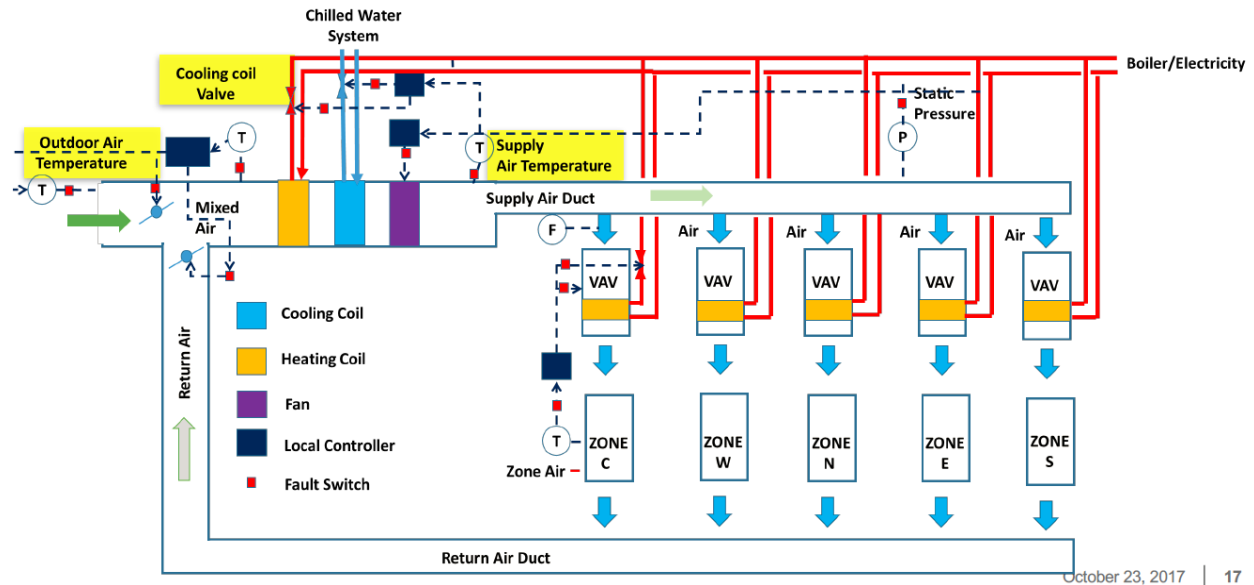

Figure 1-2. Single duct multi-zone AHU-VAV System

1.1.3 Control sequence

Below summarizes the control sequence used for the AHU and VAV systems. It is a Typical Building Control Baseline” modified based on ASHRAE 90.1-1989 and 1999.

The AHUs and VAV boxes are scheduled for automatic operation on a time of day basis for occupied and unoccupied mode. The occupied mode starts at 6am and ends at 8pm from Monday to Saturday. There are no specific holidays that are considered as unoccupied days in the dataset. There is also no dehumidify control in control sequence.

Occupied mode (Monday – Saturday 6:00am – 8:00pm)

- Fan status: The supply fan and return fan starts or continue to run.
- Supply air temperature control: The cooling coil valve shall modulate to maintain a fixed 55°F supply air temperature setpoint.
- Static pressure control: The supply fan VFD shall modulate to maintain a fixed 1-inch water static pressure set point. Return fan VFD is controlled as the same as supply fan.
- Minimum outdoor air control: When the unit is not in economizer mode, the OA damper shall be fixed at a minimum OA damper position (14% opening)
- Economizer mode: The AHU shall enter economizer mode when outdoor air temperature is below 60°F. The OA damper will modulate in sequence with return air damper to maintain the supply air temperature setpoint. The cooling coil valve will be closed. Once the OA damper is greater than 100% open. The cooling coil valve shall be enable to maintain supply air temperature setpoint
- VAV box reheating coil valve and airflow control: In cooling mode, when the zone cooling setpoint is met, VAV airflow is 30% of max flow rate; when the zone temperature is +3°F higher

than the setpoint, the damper is 100% open or max airflow rate, when zone temperature is between the setpoint and setpoint +3°F, the damper modulate so that the airflow rate is 30% and 100% of max flow rate. In heating mode, VAV airflow is 30% of max flow rate, when the zone temperature is -3°F lower than the setpoint, the heating coil valve is fully open; when the zone temperature is at zone temperature heating setpoint, the heating coil valve is 0% open. When zone temperature is between the heating setpoint and setpoint -3°F, the heating coil modulate between 0% to 100%. When the zone temperature is between zone cooling setpoint and heating setpoint, VAV airflow is 30% of max flow rate.

- Space temperature control: The zone heating and cooling setpoint are 70°F and 75°F during the occupied time period,

Unoccupied mode

- Fan status: The supply fan is off. The cooling coil valve closes and the OA damper close. The return fan is controlled as the same as supply fan. System cycling ON and OFF to maintain the unoccupied heating and cooling setpoint.
- Unoccupied heating: zone air temperature heating setpoint is 60°F.
- Unoccupied cooling: zone air temperature cooling setpoint is 80°F.

1.2 Data point summary

The data points below were recorded at 1-min interval. (Table 1-1). The *sensor points* are system setpoint, control signal and actual measurements. *Schedule point* indicates whether the system operates in occupied or unoccupied mode. *Outcome points* include *energy* and *comfort* related data which could potentially be used in the future to determine an outcome-based ground truth. *Condition-based truth* points are the points that were manipulated in the input scenarios to impose faults therefore indicating condition-based ground truths. *Control signals before overridden* are the original control signals that generated from these overridden data points and will be used as the inputs for AFDD protocols.

Table 1-1. Data points of simulated multi-zone variable air volume AHU data set

Data Point Name	Description	Unit
AHU: Supply Air Temperature	Measured AHU supply air temperature	°F
AHU: Supply Air Temperature Set Point	AHU supply air temperature set point	°F
AHU: Outdoor Air Temperature	Measured AHU outdoor air temperature	°F
AHU: Mixed Air Temperature	Measured AHU mixed air temperature	°F
AHU: Return Air Temperature	Measured AHU return air temperature	°F
AHU: Supply Air Fan Status	AHU supply air fan status; 0-off, 1-on	--
AHU: Return Air Fan Status	AHU return air fan status; 0-off, 1-on	--
AHU: Supply Air Fan Speed Control Signal	AHU supply air fan speed; ranges from 0 to 1; 0 - fan speed is 0%, 1 - fan speed is 100%	--
AHU: Return Air Fan Speed Control Signal	AHU return air fan speed; ranges from 0 to 1; 0 - fan speed is 0%, 1 - fan speed is 100%	--
AHU: Outdoor Air Damper Control Signal	Control signal for AHU outdoor air damper; ranges from 0 to 1; 0 – damper should be fully closed, 1 – damper should be fully open	--
AHU: Return Air Damper Control Signal	Control signal for AHU return air damper; ranges from 0 to 1; 0 – damper should be fully closed, 1 – damper should be fully open	--
AHU: Cooling Coil Valve Control Signal	Control signal for AHU cooling coil valve; ranges from 0 to 1; 0 – valve should be fully closed, 1 – valve should be fully open	--
AHU: Heating Coil Valve Control Signal	Control signal for AHU heating coil valve; ranges from 0 to 1; 0 – valve should be fully closed, 1 – valve should be fully open	--
AHU: Supply Air Duct Static Pressure	Measured AHU supply air duct static pressure	psi
AHU: Supply Air Duct Static Pressure Set Point	AHU supply air duct static pressure setpoint	psi
Occupancy Mode Indicator	Indicator if the system operates in occupied mode; 1-occupied mode, 0-unoccupied mode	--
Fault Detection Ground Truth	Indicator if there is a fault present during the day; 0 – unfaulted, 1 - faulted	--

1.3 Input (faulted or unfaulted) scenarios

The team simulated faulted and unfaulted scenarios on the AHU at middle floor using Typical Meteorological Year version 3 (TMY3) files for Chicago, IL, located in ASHRAE climate zone 5A (Cool, Humid). OA temperature bias faults are directly manually impose in the simulation model by overriding the control signals. Each fault lasts for one day (midnight-to-midnight). The data set is provided in “MZVAV-1.csv”.

The detailed input scenarios are shown in Table 1-2.

Table 1-2. Simulated input scenarios included in current dataset.

Input Scenarios		Fault occurred time
Fault type	Fault intensity	
Outdoor air temperature sensor bias	$x' = x + 1(^{\circ}\text{C})$	2/6/17 - 2/12/17 5/9/17-5/14/17 8/7/17-8/13/17 11/6/17-11/12/17
	$x' = x + 2(^{\circ}\text{C})$	2/13/17 - 2/19/17 5/16/17-5/21/17 8/14/17-8/20/17 11/13/17-11/19/17
	$x' = x + 4(^{\circ}\text{C})$	2/20/17 - 2/26/17 5/23/17-5/28/17 8/21/17-8/27/17 11/20/17-11/26/17
	$x' = x - 1(^{\circ}\text{C})$	2/27/17-3/5/17 5/30/17-6/4/17 8/28/17-9/3/17 11/27/17-12/3/17
	$x' = x - 2(^{\circ}\text{C})$	3/6/17-3/12/17 6/6/17-6/11/17 9/4/17-9/10/17 12/4/17-12/10/17
	$x' = x - 4(^{\circ}\text{C})$	3/13/17-3/19/17 6/13/17-6/18/17 9/11/17-9/17/17 12/11/17-12/17/17
Unfaulted		1/30/17-2/5/17 5/2/17-5/7/17 7/31/17-8/6/17 10/30/17-11/5/17

Note: x is the true value, x' is the faulty value

2. Experimental and simulated multi-zone variable air volume AHU data set

The experimental and simulated fault dataset is generated by Drexel university in ASHRAE 1312 project¹ for a small size commercial building in Iowa.

2.1 Building and system information

The simulation models developed in this project are based on the test facility at the energy resource station (ERS). The ERS is built to compare different energy efficiency measures and to record energy consumption. To perform side-by-side testing, the facility is equipped with three AHUs (Figure 2-1). AHU-1 serves the common areas of the building. The remaining AHUs serve the A- and B-Test Systems. AHU- A and B are identical, with each AHU serving four zones. Of the four zones, three have external exposures and one sees only internal conditions. The A and B zones are mirror images. The zones have identical construction and identical exposures yielding identical external thermal loads. Experiments and simulations focus on AHU-A.

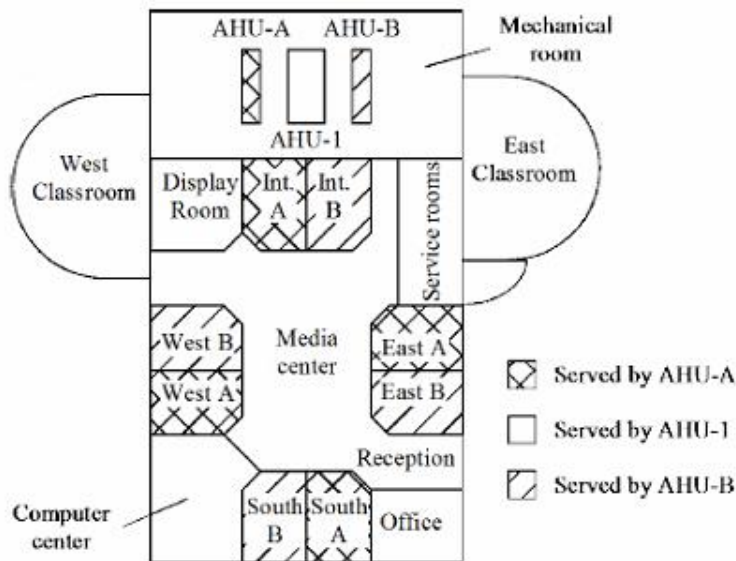

Figure 2-1. Studied energy resource station building in Ankeny, Iowa

2.1.1 System type and diagram

The major components of the Test System AHU-A, shown in Figure 2-2, are the supply air and return air fans; preheat, cooling, and heating coils; heating and cooling control valves; recirculated air, exhaust air, and outdoor air (OA) dampers; and the ducts to transfer the air to and from the conditioned spaces.

¹ Jin Wen and Shun Li, RP-1312 Tools for Evaluating Fault Detection and Diagnostic Methods for Air-Handling Units, ASHRAE report, 2012.

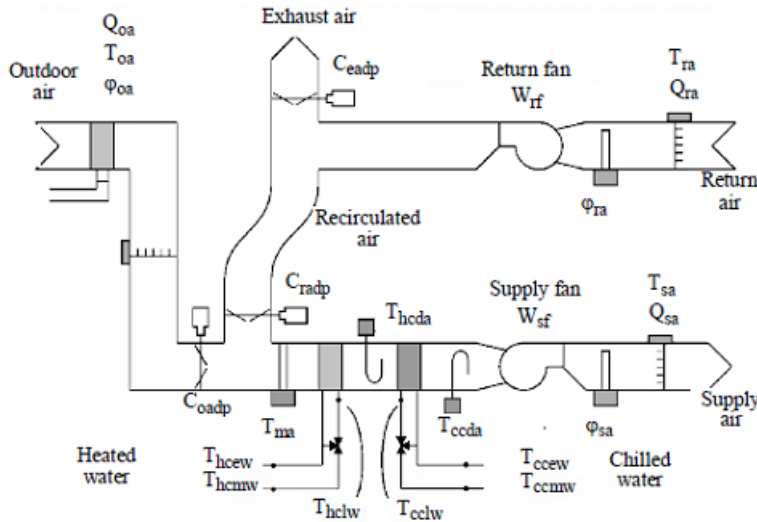

Figure 2-2. AHU-A in studied ERS building

2.1.2 Control sequence

2.1.2.1 AHU control sequence

Below summarizes the control sequence used for the AHU and VAV systems. The AHU and VAV boxes are scheduled for automatic operation on a time of day basis for occupied and unoccupied mode. There is also no dehumidify control in control sequence.

Occupied mode (Monday - Sunday 6:00am -6:00pm)

- Fan status: The supply fan and return fans start or continue to run.
- Supply air temperature control: The cooling coil valve shall modulate to maintain a fixed 55°F supply air temperature setpoint. When the outdoor air damper is in the minimum position and mechanical heating is required (output from the PI control algorithm drops below 0) causing the control sequence to switch to the mechanical heating mode. During the mechanical heating mode, the valve for the AHU heating coil is modulated to maintain a fixed 65°F supply air temperature setpoint.
- Static pressure control: The supply fan VFD shall modulate to maintain a fixed 1.4 psi static pressure set point. The return fan is operated with a speed tracking control sequence (80% of SF speed).
- Minimum outdoor air control: When the unit is not in economizer mode, the OA damper shall be fixed at a minimum OA damper position (40% opening)
- Economizer mode: The AHU shall enter economizer mode when outdoor air temperature is below 65°F. The OA damper will modulate in sequence with return air damper to maintain the supply air temperature setpoint. The cooling coil valve will be closed. Once the OA damper is greater than 100% open. The cooling coil valve shall be enable to maintain supply air temperature setpoint
- VAV box reheating coil valve and airflow control: If zone temperature is less than zone heating setpoint, then a heating case exists. The VAV damper is regulated to maintain a minimum air

flow rate, determined either for indoor air quality or equipment limitations. The reheating valve is regulated by a dual PI (DPI) algorithm to supply enough heated water flowing through the reheating coil to increase the entering air temperature to bring zone air temperature above heating setpoint. When zone air temperature is higher than the zone cooling setpoint, then a cooling case exists. The reheating valve position is at 0 %. The VAV damper is opened to bring in more supply air to cool the zone. The air flow rate entering the zone may be varied between the minimum value and the maximum value, which is the rated maximum flow rate for the VAV unit. An air flow rate setpoint is determined by scaling the DPI output between minimum and maximum values. Another PI then regulates the damper position to maintain air flow rate setpoints. Maximum air flow rate is 1000 cfm for exterior zones and 400 cfm for interior zones. Minimum air flow rate is 200 cfm for all zones

- Space temperature control: The zone heating and cooling setpoint are 70°F and 72°F during the occupied time period.

Unoccupied mode

- The fans are turned off, and the dampers and valves are indexed to a fully closed position. Fully closed dampers and valves refers to 100 % recirculation air with both the heated and chilled water valves closed.

2.2 Data point summary

The data points below were recorded at 1-min interval. Data points of simulated multi-zone variable air volume AHU data set

Table 2-1 Data points of experimental and simulated multi-zone variable air volume AHU data set

Data Point Name	Description	Unit
AHU: Supply Air Temperature	Measured AHU supply air temperature	°F
AHU: Supply Air Temperature Set Point	AHU supply air temperature set point	°F
AHU: Outdoor Air Temperature	Measured AHU outdoor air temperature	°F
AHU: Mixed Air Temperature	Measured AHU mixed air temperature	°F
AHU: Return Air Temperature	Measured AHU return air temperature	°F
AHU: Supply Air Fan Status	AHU supply air fan status; 0-off, 1-on	--
AHU: Return Air Fan Status	AHU return air fan status; 0-off, 1-on	--
AHU: Supply Air Fan Speed Control Signal	AHU supply air fan speed; ranges from 0 to 1; 0 - fan speed is 0%, 1 - fan speed is 100%	--
AHU: Return Air Fan Speed Control Signal	AHU return air fan speed; ranges from 0 to 1; 0 - fan speed is 0%, 1 - fan speed is 100%	--
AHU: Exhaust Air Damper Control Signal	Control signal for AHU exhaust air damper; ranges from 0 to 1; 0 – damper should be fully closed, 1 – damper should be fully open	--
AHU: Outdoor Air Damper Control Signal	Control signal for AHU outdoor air damper; ranges from 0 to 1; 0 – damper should be fully closed, 1 – damper should be fully open	--

AHU: Return Air Damper Control Signal	Control signal for AHU return air damper; ranges from 0 to 1; 0 – damper should be fully closed, 1 – damper should be fully open	--
AHU: Cooling Coil Valve Control Signal	Control signal for AHU cooling coil valve; ranges from 0 to 1; 0 – valve should be fully closed, 1 – valve should be fully open	--
AHU: Heating Coil Valve Control Signal	Control signal for AHU heating coil valve; ranges from 0 to 1; 0 – valve should be fully closed, 1 – valve should be fully open	--
AHU: Supply Air Duct Static Pressure	Measured AHU supply air duct static pressure	psi
AHU: Supply Air Duct Static Pressure Set Point	AHU supply air duct static pressure setpoint	psi
Occupancy Mode Indicator	Indicator if the system operates in occupied mode; 1-occupied mode, 0-unoccupied mode	--
Fault Detection Ground Truth	Indicator if there is a fault present during the day; 0 – unfaulted, 1 - faulted	--

2.3 Input (faulted or unfaulted) scenarios

The experiment and simulation were conducted in a small size commercial building in Iowa during summer, winter, and transition season. The faults were manually imposed into the control system. Each fault was tested for one day. The experimental dataset was provided in “MZVAV-2-1.csv” and the simulated dataset was provided in “MZVAV-2-2.csv”

Table 2-2. Experimental input scenarios included in the dataset for MZVAV AHU

Input Scenarios			Method of fault imposition	Fault occurred time
Fault type		Fault intensity		
Valve of Heating Coil	Leaking	Stage 1: 0.4 GPM	Manually open heating coil bypass valve	8/28/2007
		Stage 2: 1.0 GPM		8/29/2007
		Stage 3: 2.0 GPM		8/30/2007
Unfaulted				8/19/2008 8/25/2008 9/4/2008 1/19/2009 2/16/2009 2/17/2009 5/3/2009 5/4/2009 5/5/2009 5/6/2009

Table 2-2. Simulation Input scenarios included in the dataset for MZVAV AHU

Input Scenarios			Method of fault imposition	Fault occurred time
Fault type		Fault intensity		
OA Damper	Stuck	Fully closed	Automated override of control signal values to indicate that OA damper is stuck.	2/12/2008
		40% Open		5/7/2008
		45% Open		5/8/2008
		55% Open		9/5/2007
Valve of Heating Coil	Leaking	Stage 1: 0.4 GPM	Manually open heating coil bypass valve	9/6/2007
		Stage 2: 1.0 GPM		8/28/2007
		Stage 3: 2.0 GPM		8/29/2007
Valve of Cooling Coil	Stuck	Fully closed	Automated override of control signal values to indicate that cooling coil valve is stuck.	8/30/2007
		Fully open		5/6/2008
		Partially open 15%		8/31/2007
		Partially open 65%		5/15/2008
Unfaulted				9/1/2007
				9/2/2007
				8/27/2008
				8/28/2008
				8/29/2008
				8/30/2008
				8/31/2008
				9/1/2008
				9/4/2008
				9/5/2008
				2/11/2009
				5/6/2009
				5/7/2009
				5/8/2009
				5/15/2009

3. Experimental single-zone constant air volume AHU and single-zone variable air volume AHU dataset

These experimental datasets for a single zone constant air volume (SZCAV) AHU and a single zone variable air volume (SZVAV) AHU was generated by Lawrence Berkeley National Laboratory(LBNL) in LBNL's FLEXLAB test facility.

3.1 Building and system information

3.1.1 Building description

The experiments used FLEXLAB's test cell X3A. Figure 3-1 provides the facility's image and floorplan. The test cell was reserved for experiments. Internal loads that were similar to those in a real commercial building were added in the test cell with heaters controlled by plug timers. Each test cell is served by a single zone AHU. Two test cells in the same test bed share a chilled water plant and a hot water plant.

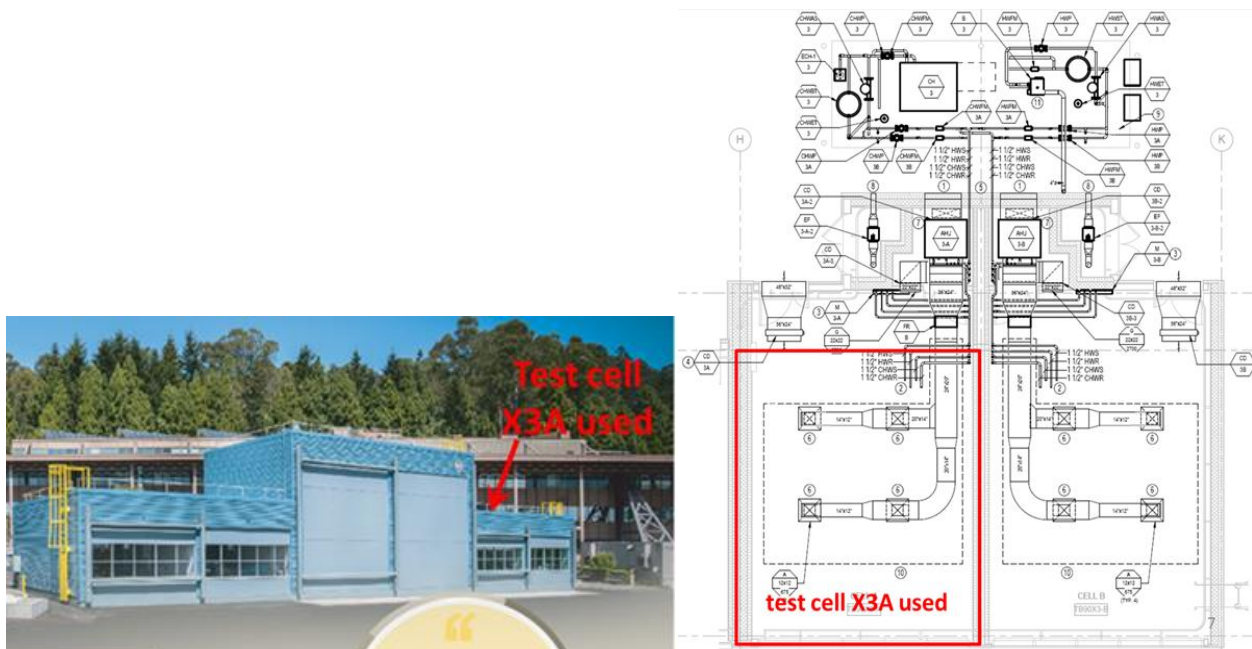

Figure 3-1. FLEXLAB Test cell X3A (left) and floorplan(right)

3.1.2 System type and diagram

The AHU that serves test cell X3A was used in the experiments. Its major components, shown in Figure 3-2, are supply air fan with a VFD, cooling and heating coils, cooling and heating control valves, outdoor air (OA), return air (RA), and exhaust air (EA) dampers. The same AHU was used as a SZCAV AHU (by fixed supply air fan speed at 50%) in winter 2017 and a SZVAV AHU in summer 2017 for data acquisition.

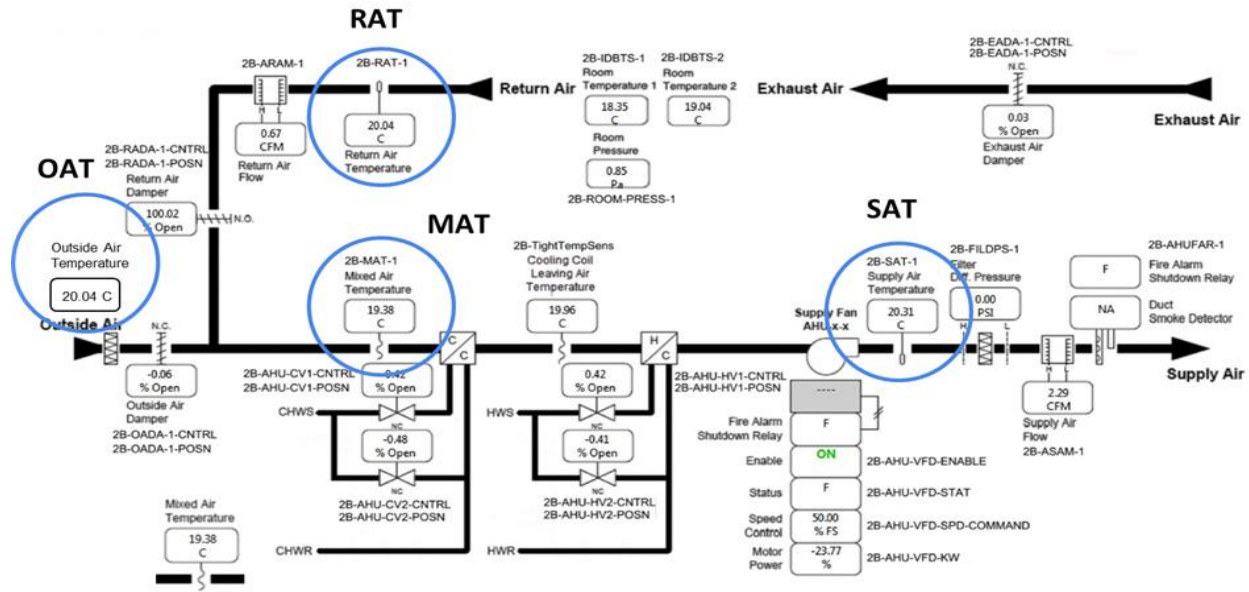

Figure 3-2. Schematic diagram of single-zone AHU in FLEXLAB

3.1.3 Control sequence

3.1.3.1 Control sequence of SZCAV AHU

Below summarizes the control sequence used for SZCAV AHU. There is no dehumidify control.

The AHU is scheduled for automatic operation on a time of day basis for occupied and unoccupied mode. The occupied mode starts at 6am and ends at 6pm.

Occupied mode (Monday-Sunday 6am-6pm)

- Fan status: The supply fan continues to run.
- Supply air temperature control: the cooling coil valve and heating coil valve shall modulate to maintain a SAT setpoint. The SAT setpoint is reset within T_min (50°F/10°C) and T_max (86°F/30°C) based on zone demand
- Supply air fan speed control: The supply fan speed is fixed at 50%.
- Minimum outdoor air control: When the unit is not in economizer mode, the OA damper shall be fixed at a minimum OA damper position (15% opening)
- Economizer mode: The AHU shall enter economizer mode when outdoor air temperature is 3.6 °F (2°C) lower than the return air temperature. The OA damper will gradually open to 100%, then RA damper will gradually close to 0% and EA damper will gradually open to 100%.
- Space temperature control: The zone heating and cooling setpoint are 71°F/21.7°C and 74°F/23.3°C during the occupied time period,

Unoccupied mode

- The supply fan is on. The OA and EA damper close and the RA damper fully open.
- Unoccupied heating: zone air temperature heating setpoint is 65°F/18.3°C.
- Unoccupied cooling: zone air temperature cooling setpoint is 80°F/26.7°C.

3.1.3.2 Control sequence of SZVAV AHU

Below summarizes the control sequence used for SZVAV AHU. It is an advanced sequence modified based on ASHRAE Guideline 36P High Performance Sequences of Operation for HVAC systems.

The AHU is scheduled for automatic operation on a time of day basis for occupied and unoccupied mode. The occupied mode starts at 6am and ends at 6pm.

Occupied mode (Monday-Sunday 6am-6pm)

- Fan status: The supply fan continues to run.
- Supply air temperature control: In cooling mode, the heating coil valve is closed and the cooling coil valve shall modulate to maintain a SAT setpoint. The SAT cooling setpoint is reset within T_min (55°F/12.8°C) and T_max (72.5°F/22.5°C) based on zone demand; In heating mode, the cooling coil valve is closed and the heating coil valve shall modulate to maintain a supply air temperature (SAT) setpoint. The SAT heating setpoint is reset within T_min (72.5°F/22.5°C) and T_max (86°F/30°C) based on zone demand. In economizer mode, the OA damper shall modulate to maintain the SAT heating setpoint.
- Supply air fan speed control: The supply fan speed is reset between minimum (10%) and maximum speed (50% in cooling mode, 30% in heating mode) based on zone demand. The minimum speed is determined to meet the ventilation with the OA damper completely open. The maximum speed is determined to provide design heating/cooling airflow for heating/cooling mode.
- Minimum outdoor air control: When the unit is not in economizer mode, the OA damper shall be fixed at a minimum OA damper position which is reset based on supply fan speed between minimum (10%) and maximum (15%). Return air damper is fully open and exhaust air damper is fully closed.
- Economizer mode: The AHU shall enter economizer mode when outdoor air temperature is 3.6 °F (2°C) lower than the return air temperature. The OA damper will open to 100%, while RA damper will gradually close to 0% and EA damper will gradually open to 100%.
- Space temperature control: The zone heating and cooling setpoint are 71°F/21.7°C and 74°F/23.3°C during the occupied time period,

Unoccupied mode

- The supply fan run at minimum speed (10%). The system operates in the same way as in occupied mode to when the space temperature beyond the unoccupied heating/cooling setpoint, and disabled when the setpoint +/- 3.6°F/2°C is achieved.
- Unoccupied heating: zone air temperature heating setpoint is 65°F/18.3°C.
- Unoccupied cooling: zone air temperature cooling setpoint is 80°F/26.7°C.

3.2 Data point summary

The data points shown below were recorded at 1-min interval.

Table 3-2. Data points of experimental SZCAV AHU and SZVAV data sets

Data Point Name	Description	Unit
AHU: Supply Air Temperature	Measured AHU supply air temperature	°F
AHU: Supply Air Temperature Heating Set Point	AHU supply air temperature heating set point	°F
AHU: Supply Air Temperature Cooling Set Point	AHU supply air temperature cooling set point	°F
AHU: Outdoor Air Temperature	Measured AHU outdoor air temperature	°F
AHU: Mixed Air Temperature	Measured AHU mixed air temperature	°F
AHU: Return Air Temperature	Measured AHU return air temperature	°F
AHU: Supply Air Fan Status	AHU supply air fan status; 0-off, 1-on	--
AHU: Supply Air Fan Speed Control Signal	AHU supply air fan speed; ranges from 0 to 1; 0 - fan speed is 0%, 1 - fan speed is 100%	--
AHU: Exhaust Air Damper Control Signal	Control signal for AHU exhaust air damper; ranges from 0 to 1; 0 – damper should be fully closed, 1 – damper should be fully open	--
AHU: Outdoor Air Damper Control Signal	Control signal for AHU outdoor air damper; ranges from 0 to 1; 0 – damper should be fully closed, 1 – damper should be fully open	--
AHU: Return Air Damper Control Signal	Control signal for AHU return air damper; ranges from 0 to 1; 0 – damper should be fully closed, 1 – damper should be fully open	--
AHU: Cooling Coil Valve Control Signal	Control signal for AHU cooling coil valve; ranges from 0 to 1; 0 – valve should be fully closed, 1 – valve should be fully open	--
AHU: Heating Coil Valve Control Signal	Control signal for AHU heating coil valve; ranges from 0 to 1; 0 – valve should be fully closed, 1 – valve should be fully open	--
Occupancy Mode Indicator	Indicator if the system operates in occupied mode; 1-occupied mode, 0-unoccupied mode	--
Fault Detection Ground Truth	Indicator if there is a fault present during the day; 0 – unfaulted, 1 - faulted	--

Note: AHU SAT heating and cooling setpoints are not available in 9/11/17 12:00am - 9:49am for SZVAV dataset

3.3 Input (faulted or unfaulted) scenarios

The team created faulted and unfaulted scenarios for SZCAV AHU and SZVAV AHU by experiments on the AHU serving test cell X3A at FLEXLAB, Berkeley, CA, located in ASHRAE climate zone 3C (Warm – Marine) . The fault types imposed on the SZCAV AHU in Winter (March 2017) include OA damper stuck and leaking, valve of heating coil stuck and leaking, and valve of cooling coil stuck and leaking. The fault types imposed on the SZVAV AHU in summer (September 2017) include OA damper stuck, valve of heating coil stuck and leaking, and valve of cooling coil stuck and leaking. Each fault was imposed to the unit at 12am and lasted for a day. The datasets are provided in “SZCAV.csv” and “SZVAV.csv” respectively.

The detailed input scenarios for are shown in Tables 3-3 and 3-4.

Table 3-3. Experimental input scenarios included in the dataset for SZCAV AHU

Input Scenarios		Method of fault imposition	Fault occurred time
Fault type	Fault intensity		
OA damper	Stuck	Fully open (100%)	3/18/17
		Partially open (50%)	3/19/17
	Leaking	20% of max damper flow	3/20/17
		50% of max damper flow	3/21/17
Valve of Heating Coil	Stuck	Fully closed (0%)	3/24/17
		Fully open (100%)	3/25/17
		Partially open (50%)	3/26/17
	Leaking	5% of max coil valve flow	3/22/17
		40% of max coil valve flow	3/23/17
Valve of Cooling Coil	Stuck	Fully closed (0%)	3/11/17
		Fully open (100%)	3/12/17
		Partially open (50%)	3/31/17
	Leaking	5% of max coil valve flow	3/15/17
		50% of max coil valve flow	3/16/17
Unfaulted		--	4/1/17

Table 3-4. Experimental input scenarios included in the dataset for SZVAV AHU

Input Scenarios			Method of fault imposition	Fault occurred time
Fault type		Fault intensity		
OA Damper	Stuck	Minimum position	Automated override of control signal values to indicate that OA damper is stuck.	9/18/17
		Fully open (100%)		9/19/17
Valve of Heating Coil	Stuck	Fully open (100%)	Automated override of control signal values to indicate that heating coil valve is stuck.	9/14/17
		Partially open(50%)		9/15/17
	Leaking	40% of max coil valve flow	Open heating coil bypass valve to 40% of the maximum heating coil valve flow.	9/12/17
Valve of Cooling Coil	Stuck	Fully open (100%)	Automated override of control signal values to indicate that cooling coil valve is stuck	9/22/17
	Leaking	50% of max coil valve flow	Open heating coil bypass valve to 50% of the maximum heating coil valve flow.	9/11/17
Unfaulted			--	9/20/17, 9/21/17, 9/23/17, 9/24/17

4. Experimental rooftop unit (RTU) data set

This experimental dataset for a RTU was generated by National Renewable Energy Laboratory(NREL) and Oak Ridge National Laboratory(ORNL) in ORNL’s light commercial flexible research platform (FRP) #2.

4.1 Building and system information

4.1.1 Building description

FRP #2 is a 3,200 ft² facility designed to emulate a 1980s-era office building. FRP #2 is reserved for experiments and is not occupied, but internal load is emulated. Figures 4-1 and 4-2 provide the facility photos and floorplans. FRP #2 has three installed heating, ventilation, and air conditioning (HVAC) systems: a single packaged RTU connected to a multi-zone VAV system, a ground source heat pump (GSHP), and a variable refrigerant flow (VRF) system.



Figure 4-1. Flexible Research Platform #2 at Oak Ridge National Laboratory

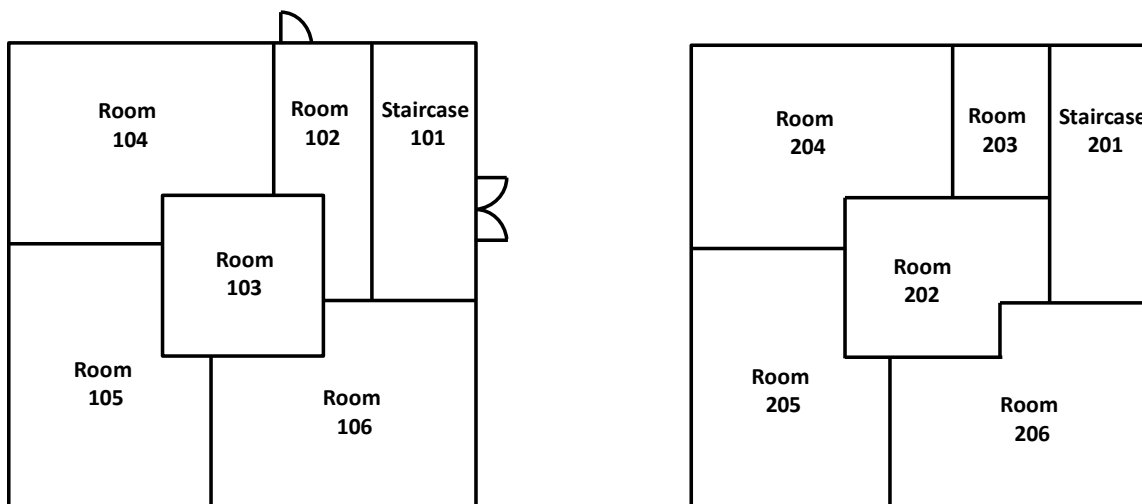

Figure 4-2. Flexible Research Platform #2 Floorplan, first floor (left) and second floor (right)

4.1.2 System type and diagram

The RTU provided heating and cooling during the experiments. The RTU is a Trane® YCD150 12.5-ton unit with an energy efficiency rating (EER) of 9.6. The connected VAV system serves a total of 10 zones (8 perimeter and 2 core) (Figure 4-3). Each VAV box includes electric resistance reheat. In this test setup, the RTU’s outdoor air intake is permanently blocked, so that there is no outside air introduced during the test.

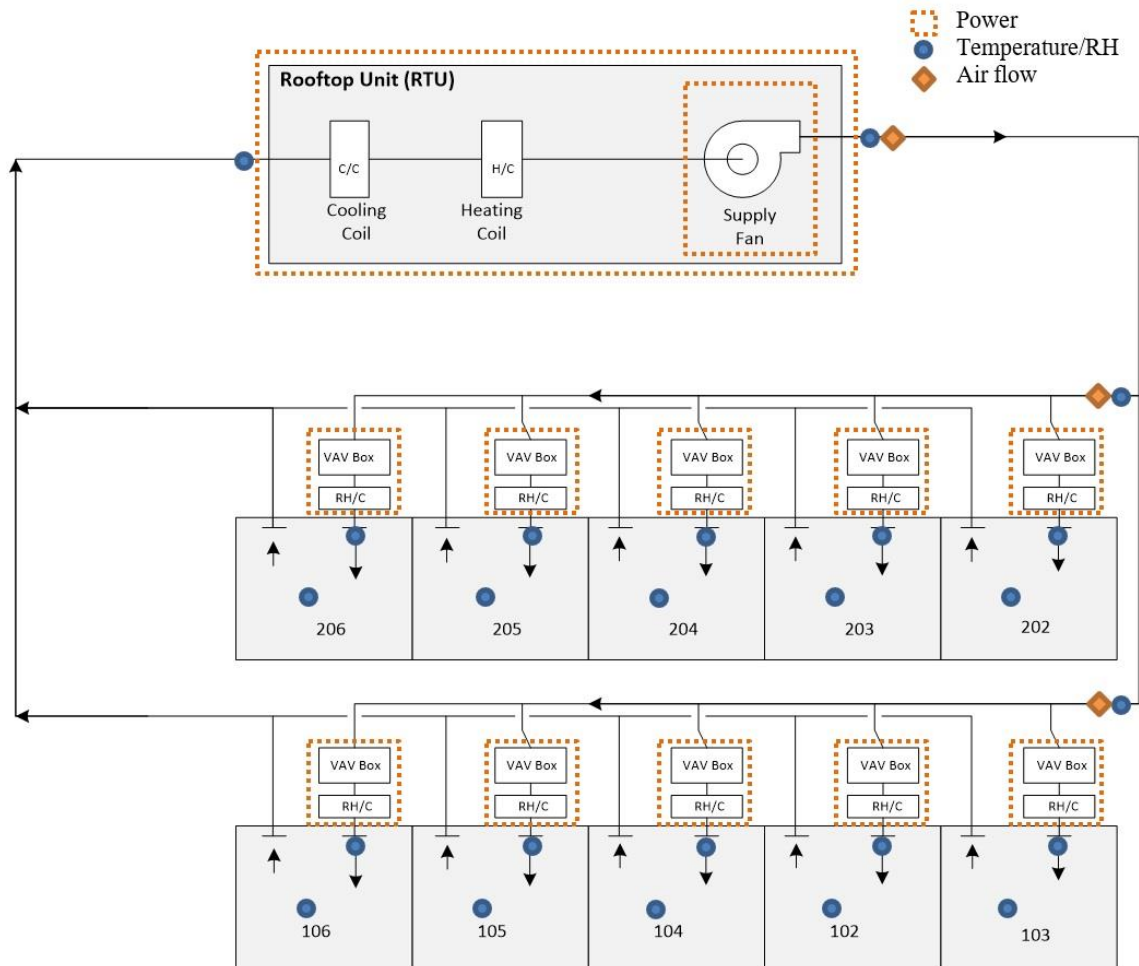

Figure 4-3. Schematic diagram of RTU and the connected ten VAV boxes that serve ten zones

4.1.3 Control sequence

Below summarizes the control sequence used for the RTU.

The AHU is scheduled for automatic operation on a time of day basis for occupied and unoccupied mode. The occupied mode starts at 7:00am and ends at 10:00pm (except condenser fouling test where it starts at 6:38am and ends at 9:38pm).

Occupied mode

- Supply air temperature control: the cooling coil valve and heating coil valve shall modulate to maintain a SAT setpoint. The SAT setpoint is 55°F year-round.
- Space temperature control: The zone heating and cooling setpoint are 69.8°F and 75.2°F during the occupied time period,

Unoccupied mode

- Unoccupied heating: zone air temperature heating setpoint is 60°F.
- Unoccupied cooling: zone air temperature cooling setpoint is 80°F.

4.2 Data point summary

The data points shown in Table 4-2 were recorded at 1-min interval.

Table 4-2. Data points of experimental RTU data sets

Data Point Name	Description	Unit
RTU: Supply Air Temperature	Measured RTU supply air temperature	°F
RTU: Return Air Temperature	Measured RTU return air temperature	°F
RTU: Supply Air Fan Status	RTU supply air fan status; 0-off, 1-on	--
RTU: Circuit 1 Discharge Temperature	Array of refrigerant temperature on the RTU	°F
RTU: Circuit 1 Condenser Outlet Temperature		
RTU: Circuit 1 Suction Temperature		
RTU: Circuit 2 Discharge Temperature		
RTU: Circuit 2 Condenser Outlet Temperature		
RTU: Circuit 2 Suction Temperature		
RTU: Circuit 1 Discharge Pressure	Array of refrigerant pressures on the RTU	PSIA
RTU: Circuit 1 Condenser Outlet Pressure		
RTU: Circuit 1 Suction Pressure		
RTU: Circuit 2 Discharge Pressure		
RTU: Circuit 2 Condenser Outlet Pressure		
RTU: Circuit 2 Suction Pressure		
RTU: Supply Air Volumetric Flow Rate	Measured RTU volumetric air flow rate	Cfm
RTU: Electricity	RTU electricity consumption	Wh
RTU: Natural Gas	RTU natural gas consumption	Cfm
Terminal: Room Air Temperature Heating Setpoint	Heating temperature setpoint of all rooms	°F
Terminal: Room Air Temperature Cooling Setpoint	Cooling temperature setpoint of all rooms	°F
Terminal: Room 102 Air Temperature	Room measured ambient temperature	°F
Terminal: Room 103 Air Temperature		
Terminal: Room 104 Air Temperature		
Terminal: Room 105 Air Temperature		

Terminal: Room 106 Air Temperature		
Terminal: Room 202 Air Temperature		
Terminal: Room 203 Air Temperature		
Terminal: Room 204 Air Temperature		
Terminal: Room 205 Air Temperature		
Terminal: Room 206 Air Temperature		
Terminal: Room 102 Air Humidity	Room measured ambient relative humidity	%
Terminal: Room 103 Air Humidity		
Terminal: Room 104 Air Humidity		
Terminal: Room 105 Air Humidity		
Terminal: Room 106 Air Humidity		
Terminal: Room 202 Air Humidity		
Terminal: Room 203 Air Humidity		
Terminal: Room 204 Air Humidity		
Terminal: Room 205 Air Humidity		
Terminal: Room 206 Air Humidity		
HVAC System: Electricity	Total electricity consumption of HVAC system including RTUs and VAV terminal reheat	Wh
Lighting System: Electricity	Total electricity consumption of lighting system	Wh
Occupancy Mode Indicator	Indicator if the system operates in occupied mode; 1-occupied mode, 0-unoccupied mode	--
Lighting System: Control Command	Control command of lighting system; 0 – off, 1 - on	--
RTU: Compressor 1 On/Off Status	RTU compressor status; 0 – off, 1 - on	--
RTU: Compressor 2 on/Off Status		
RTU: Fan Electricity	RTU supply air fan electricity consumption	Wh
VAV Box: Room 102 Reheat Status	Room VAV box reheat status; 0 – off, 1 - on	--
VAV Box: Room 103 Reheat Status		
VAV Box: Room 104 Reheat Status		
VAV Box: Room 105 Reheat Status		
VAV Box: Room 106 Reheat Status		
VAV Box: Room 202 Reheat Status		
VAV Box: Room 203 Reheat Status		
VAV Box: Room 204 Reheat Status		
VAV Box: Room 205 Reheat Status		
VAV Box: Room 206 Reheat Status		
VAV Box: Room 102 Air Temperature	Room VAV box supply air temperature	°F
VAV Box: Room 103 Air Temperature		
VAV Box: Room 104 Air Temperature		
VAV Box: Room 105 Air Temperature		
VAV Box: Room 106 Air Temperature		
VAV Box: Room 202 Air Temperature		
VAV Box: Room 203 Air Temperature		
VAV Box: Room 204 Air Temperature		
VAV Box: Room 205 Air Temperature		
VAV Box: Room 206 Air Temperature		

Fault Detection Ground Truth	Indicator if there is a fault present during the day; 0 – unfaulted, 1 - faulted	--
------------------------------	---	----

4.3 Input (faulted or unfaulted) scenarios

The team created faulted and unfaulted scenarios at FRP #2, Oak Ridge, TN, located in ASHRAE climate zone 4A (mixed – humid). The fault type imposed on the RTU is condenser fouling. The fault was imposed to the unit at 12am and lasted for a day. The dataset is provided in “RTU.csv”.

The detailed input scenarios are shown in Table 4-3.

Table 4-3. Experimental input scenarios included in the dataset for RTU

Input Scenarios		Method of fault imposition	Fault occurred time
Fault type	Fault intensity		
Condenser Fouling	25% reduction in condenser coil air flow full load	Cover the condenser face using screen, mesh, or cloth	8/27/17
	50% reduction in condenser coil air flow full load		8/29/17
HVAC Setback Error: Delayed Onset	3-hour onset delay	Modify the control programming	12/1/17
HVAC Setback Error: Early Termination	3-hour early termination	Modify the control programming	12/3/17
Excessive infiltration	+20% infiltration	Open windows to achieve target infiltration area	12/7/17
	+40% infiltration		12/14/17
Lighting Setback Error: Delayed Onset	3-hour onset delay	Modify the control programming	2/7/18
Lighting Setback Error: Early Termination	3-hour early termination	Modify the control programming	2/9/18
No Overnight HVAC Setback	No setback	Modify the control programming	12/20/17

No Overnight Lighting Setback	No setback	Modify the control programming	2/18/18
Thermostat measurement bias	Bias of +4°F (Core zone 103)	Adjust the temperature set point	2/1/18
	Bias of -4°F (Core zone 103)		1/31/18
	Bias of +4°F (Perimeter zone 205)		1/28/18
	Bias of -4°F (Perimeter zone 205)		1/27/18
Unfaulted			9/1/17, 11/30/17, 12/3/17, 12/9/17, 12/24/17, 2/4/18, 2/5/18